



MODEL

NP-7A (NP-7H)

PORTABLE FILLED BAG CLOSING MACHINE

INSTRUCTION MANUAL / PARTS LIST

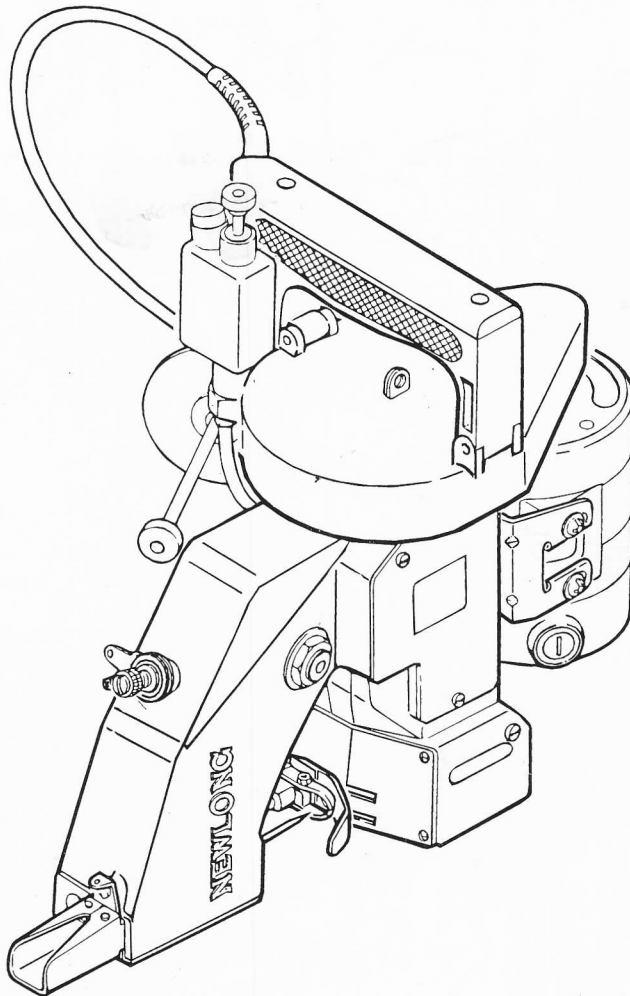

ニューロング株式会社
NEWLONG MACHINE WORKS, LTD.

No.32

ACHTUNG

VERLETZUNGSGEFAHR BEI NICHT BEACHTEN DER FOLGENDEN VORSICHTSMASSNAHMEN !

1. DIE UMGEBUNG DER MASCHINE MUSS FREI SEIN VON GEFAHREN QUELLEN WIE FEUER, WASSER, ÖL, ABFALL UND ALLEN ANDEREN DINGEN, DIE VERLETZUNGEN VERURSACHEN KÖNNEN.
2. BENÜTZEN SIE DIE MASCHINE NICHT IN DER UMGEBUNG VON EXPLOSIVEN ODER WASSER. DIE MASCHINE IST NICHT GEGEN EXPLOSIONEN ODER WASSER GESCHÜTZT.
3. VOR DEM BEDIENEN DER MASCHINE ESRT BEDIENUNGSANLEITUNG LESEN.
4. DIE MASCHINE NUR AN ZUGELASSENE NETZSPANNUNG ANSCHLIESSEN.
5. DIE MASCHINE MUSS GEERDET SEIN.
6. DIE MASCHINE MUSS VON NETZSPANNUNG (UND LUFTVERSORGUNG) GETRENNT WERDEN, BEVOR WARTUNGSARBEITEN, JUSTAGEN UND REINIGUNG DURCHGEFÜHRT WERDEN KÖNNEN.
7. DIE MASCHINE DARF NICHT OHNE SCHUTZHAUBEN UND ABDECKUNGEN BETRIEBEN WERDEN.
8. MESSER, NADEL, RIEMENSCHNUR, RIEMEN UND ALLE BEWEGLICHEN TEILE NICHT BERÜHREN WENN DIE MASCHINE LÄUFT.
9. DIE MASCHINE SOLLTE AUCH FÜR WARTUNG, JUSTAGE, REINIGUNG ODER LAGERUNG AUF SAUBEREM UND EBENEM UNTERGRUND STEHEN.
10. DAS ZU VERWENDENDE MATERIAL MUSS DEN MASCHINENANGABEN ENTSPRECHEN.
11. NUR ORIGINAL "NEWLONG" ERSATZTEILE VERWENDEN.

AVERTISSEMENT

ATTENTION À CE QU'EN CAS DE NE PAS OBSERVER LES ARTICLES DE SÉCURITÉ CI-DESSOUS, CA PEUT PROVOQUER UN ACCIDENT.

1. VÉRIFIEZ S'IL N'Y A PAS, AUTOUR DE LA MACHINE, DE TELLE CHOSE QUI PEUT PROVOQUER UN ACCIDENT COMME LE FEU, DE L'EAU, DE L'HUILE OU DE LA MATIÈRE COMBUSTIBLE.
2. CETTE MACHINE N'EST NI INEXPLOSIBILISÉE NI IMPERMÉABILISÉE, DONC NE L'UTILISEZ PAS À UNE PLACE QUI COMPORTE UN RISQUE D'EXPLOSION OU QUI A UNE POSSIBILITÉ DE SE MOUILLER.
3. NE MANQUEZ PAS DE LIRE LE MANUEL D'INSTRUCTION AVANT DE METTRE LA MACHINE EN MARCHÉ.
4. NE METTEZ PAS LA MACHINE EN MARCHÉ AVEC UN AUTRE VOLTAGE QUE CELUI D'INDIQUÉ.
5. VÉRIFIEZ SI LA PRISE DE TERRE EST CORRECTEMENT CONNECTÉE.
6. NE MANQUEZ PAS DE COUPER LE COURANT (ET LE GAZ COPRIMÉ) AVANT L'ENTRETIEN, LE CHANGEMENT DE PIÈCE, LA MISE AU POINT OU LE NETTOYAGE DE LA MACHINE.
7. NE METTEZ PAS LA MACHINE EN MARCHÉ AVEC LE COUVERCLE OU LA COUVERTURE ENLEVÉ(E).
8. NE TOUCHEZ PAS TELLES PARTIES QUI BOUGENT COMME LE COUPOIR, L'AIGUILLE, LA POULIE, LA COURROIE ETC. PENDANT LA MISE EN MARCHÉ DE LA MACHINE.
9. LORS DE L'ENTRETIEN, LE CHANGEMENT DE PIÈCE, LA MISE AU POINT OU LE MAINTENANCE DE LA MACHINE, METTEZ-LA À UNE PLACE PLATE.
10. VÉRIFIEZ SI VOTRE MATIÈRE À COUDRE S'ADAPTE À LA SPÉCIFICATION DE LA MACHINE.
11. N'EMPLOYEZ PAS D'AUTRE PIÈCE QUE CELLE DE CONVENABLE DE "NEWLONG".

CONTENS

1. SPECIFICATIONS	2
2. THE POINTS BEFORE OPERATION	2
3. PREPARATION FOR START	3
1. Oiling	3
2. Needle Setting	3
3. Threading	3
4. START	4
5. ADJUSTMENTS	5
1. Thread Tension	5
2. Position of Needle and Loper	5
3. Position of Feed Dog	5
4. Pressure of Presser Foot	5
5. Presser Foot Lifter	5
6. How to use Hook	5
6. REPLACING PARTS	6
7. LUBRICATOR	7
1. Operation	7
2. Maintenance	7
3. Troubleshooting	7
8. MAINTENANCE	8
9. ORDERING PARTS	9
NUMERICAL INDEX OF PARTS	26,27
DIAGRAM OF SCREW, NUT & WASHER	28

3. PREPARATION FOR START

1.Oiling (Fig.1)

Oiling is imperative to keep the machine in good operating condition. Pour oil in the reservoir (capacity 45 cc). To begin the flow of oil to the machine, push the button of the lubricator ten times continuously before starting the machine. This should dispense enough oil for an average running of four hours under normal operating conditions. Do not run the machine without oil as it could causes a machine failure or break down.

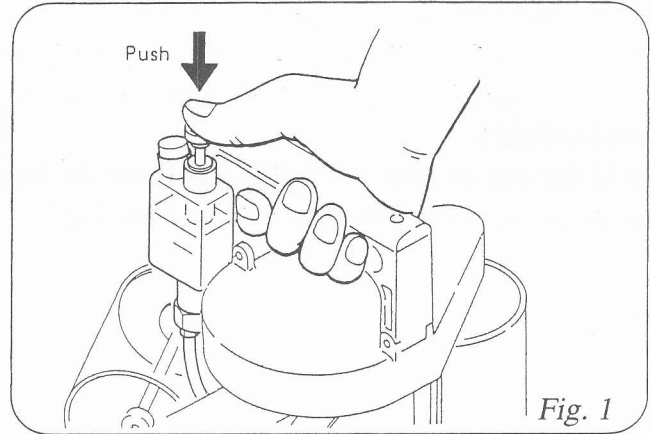

Fig. 1

2.Needle Setting (Fig.2, 3, 4)

Turn the pulley until Needle Bar reaches its highest position. Loosen Needle Bar Clamping Nut, and set Needle in the Bar as deep as it will go.

Be sure to set a Needle with its concave part facing correctly toward the Loper. Fix Clamping Nut tightly, otherwise Needle may come loose during operation and break.

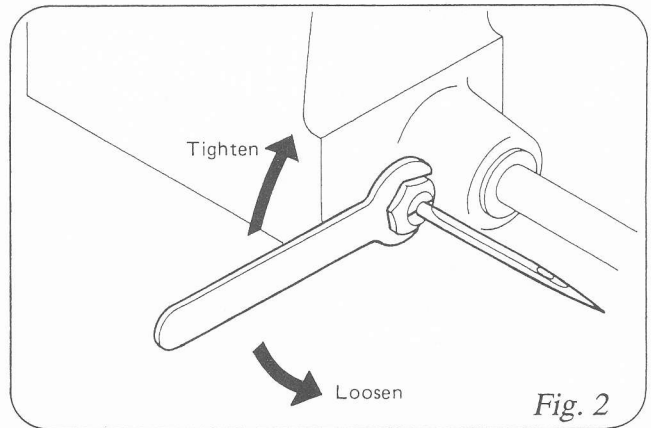

Fig. 2

3.Threading(Fig.5)

The machine is delivered being threaded to show you proper threading of the machine, which is shown in Fig.5, for identification. Follow the guide numbers 1 to 7 of Fig.5.

- ①,② Thread Eyelet
- ③ Tension Disc
- ④ Thread Eyelet
- ⑤ Needle Bar
- ⑥ Thread Eyelet
- ⑦ Needle

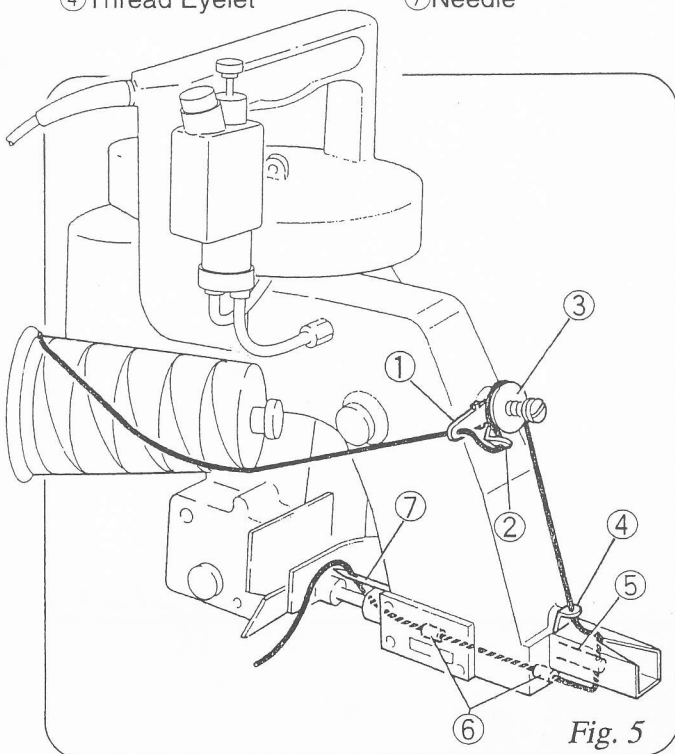

Fig. 5

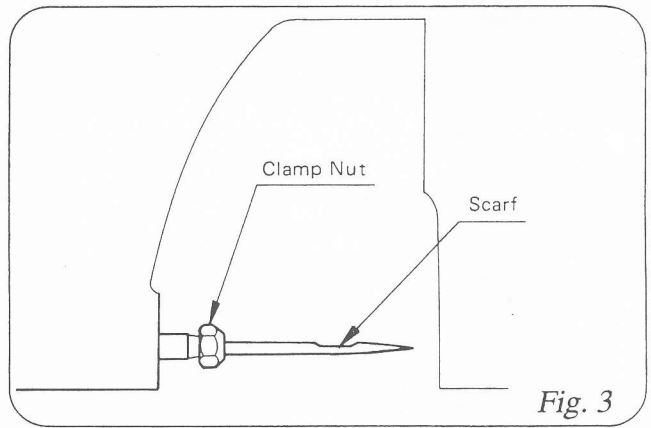

Fig. 3

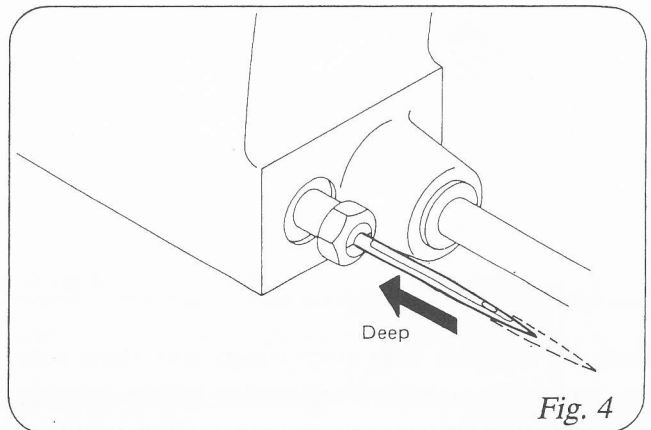

Fig. 4

5. ADJUSTMENTS

Important !

When adjusting the machine or replacing parts, always disconnect the Electric Cord from the power source.

This is important in view of safety to the operator and adjuster.

1. Thread Tension (Fig.10)

The thread tension spring is preset at the factory to sew PP woven cloth bags. If some adjustment is needed, first loosen screw (A) (9/64S40005) and adjust the thread tension nut (B) (245092) as per Fig.10. When the adjustment is finished, retighten screw to lock the thread tension nut.

If this is not done, the stitch will not remain uniform.

2. Position of Needle and Loper (Fig.11)

Looper must pass the concave part of Needle with clearance of 0.1 mm as shown in Fig.11. Adjustment of the clearance can be done after loosening the screw of Loper Rocker.

3. Position of Feed Dog (Fig.12)

When installing a new feed dog ensure that it is positioned correctly onto the feed dog carrier block and lightly tighten the fixing screw. Check that the feed dog teeth are 2.8mm above the throat plate when the feed dog is in the highest position before final tightening of the fixing screw.

4. Pressure of Presser Foot

When to adjust the pressure of Presser Foot, take out Needle Bar Guard and loosen Screw of Presser Bar Connection. Move up Presser Bar to increase the pressure and down to decrease. After the adjustment, tighten the Screw firmly.

5. Pressure Foot Lifter

The Presser Foot Lifter is used to lift the Presser Foot and pull out a bag from under the Presser Foot in case of a problem such as bag or thread jamming.

6. How to use Hook (Part No.241151)

The Hook on the Pulley Cover is used to install a Shoulder Belt or a Hanger.

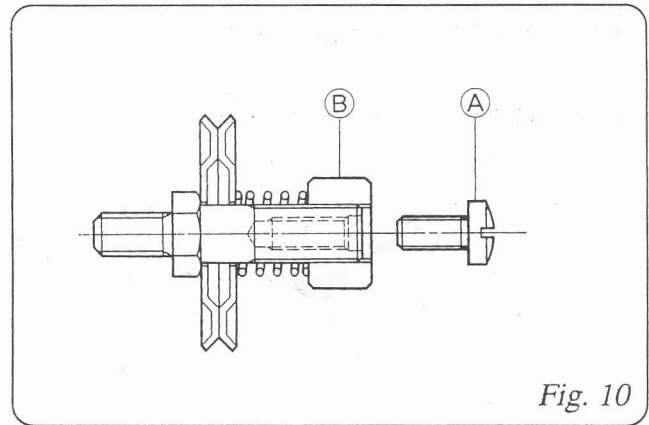

Fig. 10

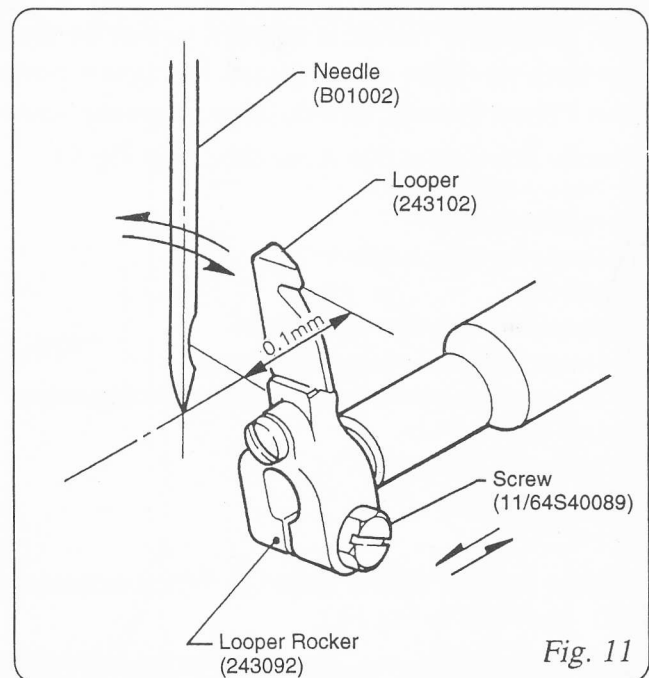

Fig. 11

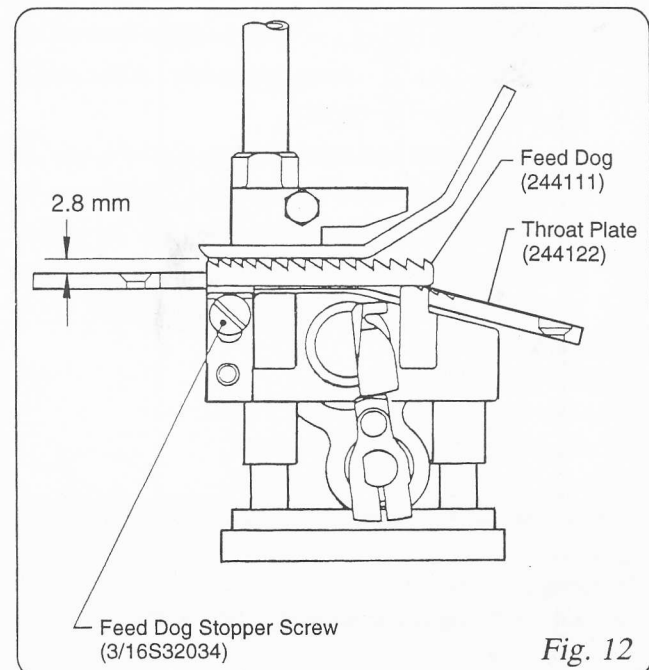

Fig. 12

7. LUBRICATOR

1. Operation

The lubricator comprises a pump and a reservoir. The reservoir holds max 45 cc of oil. (Effective oil volume is 28 cc.)

Use mineral oil 22 - 32 cSt at 40°C (Eg. Tellus oil #32).

To operate the lubricator:

1. First unscrew the reservoir cap by half a turn.*
2. Push the button to its lowest position (stroke: 12mm).
3. When released, the button will automatically return to its original position.
4. Lastly, tighten the cap to prevent oil leak during operation.

* Repeated working on the button without first loosening the cap may produce negative pressure in the reservoir, and the dust in the atmosphere may be easily introduced in it when the cap is loosened.

2. Maintenance

1. Keep off dust or foreign matter when to fill oil (They may cause jamming of the piston and the check valve).
2. Rate of discharge is fixed and not adjustable (0.08cc per push).
3. At high temperatures, grease may run along points (A). This is normal, grease being used when the lubricator was assembled in our plant.
4. Reservoir is made of high density polyethyiene. Keep off fire and refrain from using organic, benzene, or xylene chemicals for cleaning. Check periodically for correct working of the pump. (Repeat oil feed and look at the oil through the discharge pipe.)

3. Troubleshooting

Trouble	Cause	Remedy
Oil not fed.	Low oil level.	Fill oil.
Full stroke movement not obtainable.	Dust attached on the interior wall of the pumping chamber.	Replace lubricator.
Button will not return.	Dust accumulated, or break of spring.	Replace lubricator.
Oil leak from (A)	Wornout or displaced seal of O-Ring.	Replace lubricator.
Oil leak from (B)	Wornout or displaced seal of packing.	Replace lubricator.
Oil leak from (C)	Loose plug.	Tighten plug or Replace lubricator.

PUSH-BUTTON LUBRICATOR Model: NP-7A

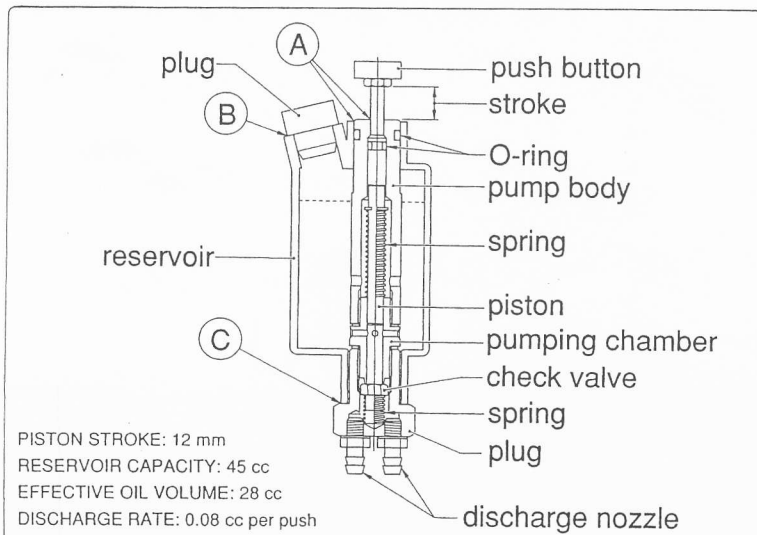

8 . MAINTENANCE

Clean the machine at the end of the day's work, and oil the bushings, shaft, etc. that are not lubricated by a lubricator. Wipe dust and other foreign matter off the Feed Dog teeth Looper and Throat Plate eyelet where they are easily gathered.

Care should be taken to keep the machine free from dust, especially when to leave it unused for some time.

Important !

The motor body should not be opened for the maintenance.

When adjusting the machine or replacing parts, always disconnect the Electric Cord from the power source.

This is important in view of safety to the operator and adjuster.

[NOTES ON CARRYING AND STORAGE]

1. Carry the machine in a storage box.
2. After the use of the machine, remove the plug, clean the dirt, take the thread from the machine and then put it into a storage box.
We suggest you to use a soft brush to clean the rear of the machine.
3. Never store the machine under the sunlight dried or wet condition.

[CAUTION]

When operate the machine, do not put it on the table. The machine is not a table top type.

6. REPLACING PARTS

For replacement or adjustment of Ball Rod, refer to Fig.13.

Take out Screw ① and disconnect Rod End ② from Needle Bar Lever ③. After loosening the Nut ④, adjust the clearance between Connecting Rod ⑤ and Rod End ②, so that Needle Bar moves in the center of the clearance between the upper and lower Presser Bar Bushings. (Needle Bar stroke is 37 mm).

To fix Eccentric Cam ⑦ on Main Shaft ⑧, tighten the Screws ⑨ and ⑨ on Main Shaft ⑧ (Eccentric Cam ⑦ should contact Spacer ⑩ slightly.). The position of Needle is adjusted so that the distance between the point of Needle (at its highest position) and Throat Plate is 13 mm, after loosening screw on Needle Bar Connection Assembly ⑥ in Fig.13.

① Screw 11/64S40084

② Rod End 6A04001

③ Needle Bar Lever 242051A

④ Nut 1N8

⑤ Connecting Rod Assembly 242011A

⑥ Needle Bar Connection Assembly 242101A

⑦ Eccentric Cam (part of Connecting Rod Assembly) 242011

⑧ Main Shaft 241102

⑨ ⑨ Screw 11/64S40001

⑩ Spacer 241161

Adjust Looper Drive Cam ③ When necessary as follows: (Refer to Fig.14.).

a) Apply the Screws ② and ② on the taper of Main Shaft ①.

b) Adjust Arm (B) ④, so that Looper Drive Cam ③ and Arm (A) ⑤ move smoothly. After adjusting, fix the Screw ⑥ tightly.

c) The clearance between Looper Drive Cam ③ and Arm ⑤ is effected by Spring ⑦. Loosen Screw ⑨ and turn Spring Supporter ⑧ to adjust the pressure of Spring ⑦. After adjusting, tighten the Screw ⑨ to fasten Spring Supporter ⑧.

① Main Shaft 241102

② ② Screw 15/64S28524

③ Looper Drive Cam 243012

④ Looper Rocker Shaft Arm (B) 243081

⑤ Looper Rocker Shaft Arm (A) 243071

⑥ Screw for Looper Rocker Shaft Arm (B) 11/64S40009

⑦ Spring 243131

⑧ Spring Supporter 243121

⑨ Screw for Spring Supporter Block 11/64S40003

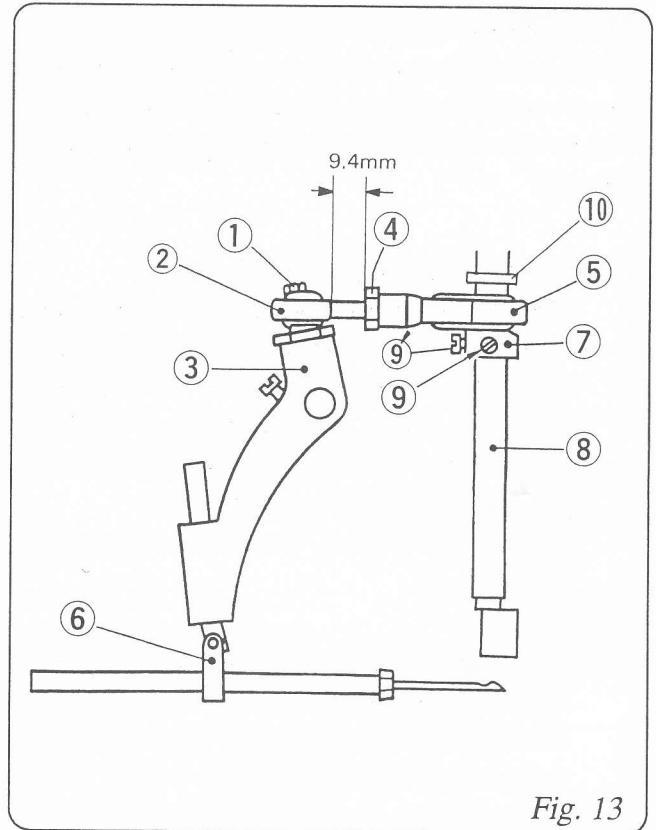

Fig. 13

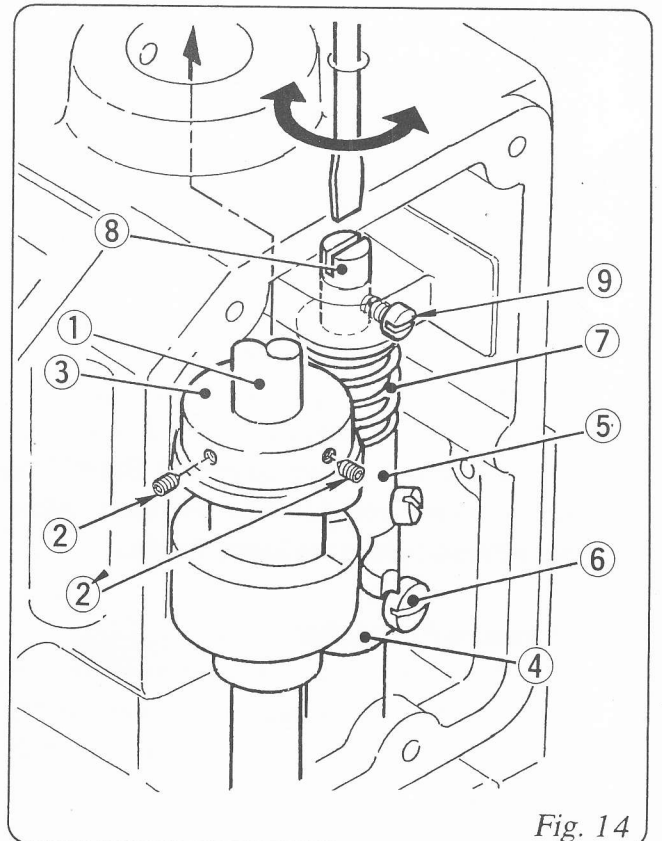

Fig. 14

1. SPECIFICATIONS

- This Bag Closing Machine is designed for use in the light industries.

TECHNICAL DETAILS

Speed(sec/bag)	5 - 6
Seam	Single Thread Chain Stitch
Stitch Range(mm.)	8.5 (fixed)
Revolution(rpm.)	1,600±125
Needle	DN×1 - #25
Thread(vinylon,synthetic or cotton)	20/6
Bag Material To Be Closed	Kraft Paper, PP/PE Woven Cloth, Cotton, Hessian, Jute
Drive Motor	220V(65W), 230V ~ 240V(70W)

Power Supply	<input type="checkbox"/> 220V., A.C. (Output 65W)
	<input type="checkbox"/> 230V ~ 240V., A.C. (Output 70W)
	50 - 60Hz,Single Phase

Net Weight(kg)	6 kgs Including Thread Cone.
Machine Dimension(mm.)	361(L)×246(W)×321(H)
Packing Dimension(cft.)	2.5

■ STANDARD ACCESSORIES

1. Needles DN×1-#25. 5 pcs.
2. Thread Vinylon 20/6
3. Screw Driver
4. Needle Bar Spanner
5. Oil
6. Hexagon Socket Screw
7. Screw Driver

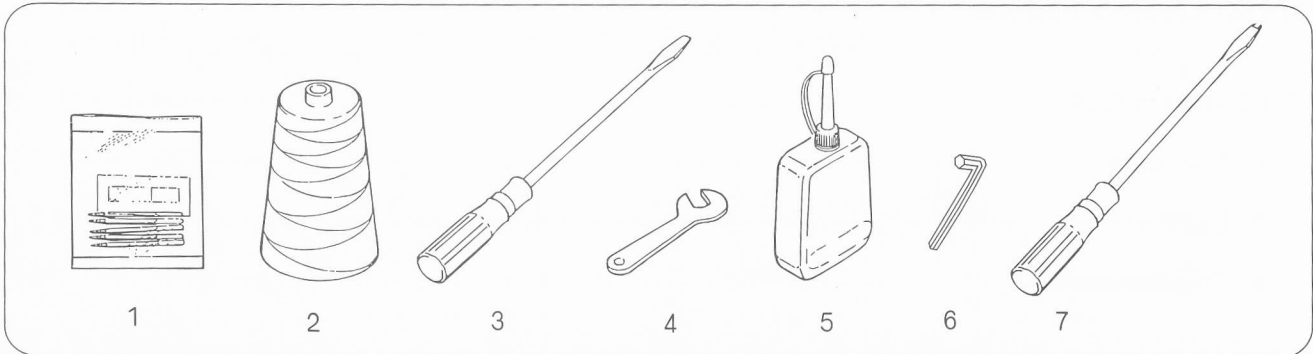

2. THE POINTS BEFORE OPERATION

- Oil the area through which thread passes, the tension disc, the thread guide, looper, etc.
(Note:An anticorrosive agent is applied to the machines at the factory, in order to prevent rusting. It is necessary to use oil to remove this agent. or it may prevent the thread from passing smoothly.)
- Confirm that the machine has been threaded as per Fig,5 in the manual.
- Confirm that the machine has been lubricated as per Fig.1 in the manual.

WARNING

PERSONAL INJURY MAY RESULT IF THE FOLLOWING SAFETY PRECAUTIONS ARE NOT OBSERVED.

1. BE SURE THE AREA SURROUNDING MACHINE IS FREE OF ALL HAZARDS SUCH AS FIRE, WATER, OIL, RUBBISH OR ANYTHING THAT CAN CAUSE INJURY.
2. DO NOT OPERATE MACHINE IN AN EXPLOSIVE AREA OR UNDER WET CONDITIONS. THE MACHINE IS NOT AN EXPLOSION - PROOF TYPE NOR WATER-PROOF.
3. DO NOT OPERATE MACHINE BEFORE READING INSTRUCTION MANUAL.
4. DO NOT OPERATE MACHINE ON VOLTAGES OTHER THAN SPECIFIED FOR THE MACHINE.
5. BE SURE MACHINE IS CONNECTED TO BUILDING ELECTRICAL SAFETY GROUND (EARTH).
6. BE SURE POWER (AND AIR SUPPLY) IS OFF BEFORE PERFORMING MACHINE MAINTENANCE, PARTS REPLACEMENT, ADJUSTMENTS OR CLEANING.
7. DO NOT OPERATE MACHINE WITH GUARDS AND COVERS REMOVED.
8. DO NOT TOUCH KNIFE, NEEDLE, PULLEY, BELT AND MOVING PARTS WHEN MACHINE IS IN OPERATION.
9. BE SURE MACHINE IS PLACED ON A SMOOTH (LEVEL) SURFACE WHEN PERFORMING MAINTENANCE, PARTS REPLACEMENT, ADJUSTMENTS, CLEANING OR STORAGE.
10. BE SURE THE MATERIAL TO BE SEWN OR CLOSED COMPLIES WITH THE MACHINE SPECIFICATIONS.
11. DO NOT USE SPARE PARTS OTHER THAN "NEWLONG" GENUINE PARTS.

PRECAUCION

NO SEGUIRLAS INSTRUCCIONES QUE SE DETALLAN PUEDE RESULTAR PERJUDICIAL PARA SU SALUD.

1. ASEGURARSE QUE ALREDEDOR DE LA MAQUINA. NO HAYA NINGUN ELEMENTO COMO FUEGO, AGUA, ACEITE U OTROS QUE PUEDAN OCASIONAR ALGUN ACCIDENTE.
2. NO USAR LA MAQUINA EN NINGUN AREA QUE TENGA RIESGO DE EXPLOSION O BAJO CONDICIONES DE HUMEDAD. LA MAQUINA NO ES SOLO EL TIPO A PRUEBA DE EXPLOSION, SINO EL TIPO A PRUEBA DE AGUA.
3. USAR LA MAQUINA, DESPUES DE HABER LEIDO CON DETENIMIENTO EL MANUAL DE INSTRUCCIONES.
4. NO USAR LA MAQUINARIA CON VOLTAJES DIFERENTES A LOS ESPECIFICADOS PARA LA MISMA.
5. ASEGURARSE DE QUE LA MAQUINA ESTA CONECTADA A UNA ZONA ELECTRICA DE SEGURIDAD CON TOMA DE TIERRA.
6. ASEGURARSE DE DESCONECTAR LA MAQUINA ANTES DE PROCEDER A SU MANTENIMIENTO, SUSTITUCION DE PIEZAS, AJUSTE Y LIMPIEZA DE LA MAQUINA.
7. NO USAR LA MAQUINA CON OBJETOS EXTRANOS, NI CUANDO TENGA UNA TAPADERA ABIERTA.
8. NO TOCAR LAS CUCHILLAS, AGUJAS, POLEAS, CORREAS Y PARTES MOVILES CUANDO LA MAQUINA ESTA EN FUNCIONAMIENTO.
9. ASEGURARSE DE QUE LA MAQUINA ESTA EN UN LUGAR APROPIADO PARA PROCEDER AL MANTENIMIENTO, RECAMBIO DE PIEZAS, AJUSTES, LIMPIEZA O ALMACENAJE.
10. ASEGURARSE DE QUE EL MATERIAL A COSER ENTRA DENTRO DE LAS ESPECIFICACIONES DE LA MAQUINA.
11. NO USAR NINGUNA PIEZA DE RECAMBIO QUE NO SEA NEWLONG.

- The part list is subject to change without prior notice.

SEW EUROPE

88 RICE LANE

LIVERPOOL L9 1DD UK

Tel: 0151 525 0511

e-mail: sew-europe@btconnect.com

Newlong NP-7A Machines, Thread, Service & Replacement Parts